



Creating an Entomology Project



What kind of project can you do with insects?

You can do all kinds of projects with insects, ranging from beginner to advanced. Your project will help you learn more about the science of entomology. Making an insect collection is an important part of your project, but also consider learning more about insect biology, behavior, or economic importance. Start by making a goal for yourself. Examples include:

I want to learn more about insects in corn.

I want to understand the importance of pollinators in Iowa.

Insects are cool, interesting animals and make great 4-H projects!

Use additional resources to help get you started thinking about your goals and the fun things that you can learn about insects!

Find Entomology Project Activity Guides at www.extension.iastate.edu/store/

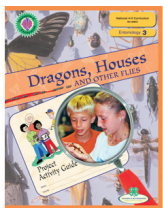

Bug Watchers (4H 423A)

What's Bugging You? (4H 423B)

Dragons, Houses and Other Flies (4H 423C)

The Group Helpers Guide (4H 423LDR)

If the store is out of stock, here is another order resource: www.4-hmall.org/Category/4-hcurriculum-entomology.aspx

Your exhibit will be judged in several categories. Try to address all these questions in your display:

- What was the goal of your project and exhibit?
- What were the most important things you learned as you worked toward this goal?
- What skills did you learn while doing this exhibit?
- What were decisions and challenges that you faced and how did you handle them?
- What worked, what didn't?
- List the resources that you used.
- What did you learn about insects?
- How did this exhibit help you better understand the relationship between nature and people?
- What would you like to do on this project area next year?

Remember neatness counts!

- Was the project completed and does it have a finished appearance?
- Was the workmanship constant and neat?
- Did you consider the appearance from a distance?
- Did you follow guidelines for making a proper insect collection?

Fair note:
You cannot bring live insects for an entomology exhibit!



.....

Listed below are some exhibit ideas

Clover Kids: grades K-3

1. Draw your favorite insects and label their body parts.
2. Display useful products made by insects.
3. Make original artwork using insects as the main theme.
4. Create a diary of insects you see in your backyard or at a park. Take notes over several weeks and include drawings of the insects in their habitat.

Junior 4-H members: grades 4-6

1. Collect and display different insect nests and the insects that built them.
2. Make and display a traditional insect collection.
3. Make a working exhibit to demonstrate the various ways insects communicate with each other.
4. Make a diorama of insect relatives (e.g., spiders, ticks, mites) showing their habitats.

Intermediate 4-H members: grades 7-8

1. Make a working exhibit on the construction of an insect net, viewing jar, or other collection devices.
2. Study the role of insects in movies, television, or music and summarize your opinions in a video. Or critique an insect-related movie and describe the accuracy (or inaccuracy!).
3. Make a mural of an Iowa landscape that features the importance of insects.
4. Make an expanded insect collection. Examples include grouping insects according to whether they are destructive, beneficial, or of no economic importance. Or show insects at various life stages and make a display comparing these differences.
5. Study the various methods insects use to defend themselves, and make a comic book that includes drawings and descriptions of these behaviors.

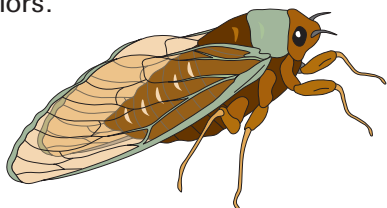

Senior 4-H members: grades 9-12

1. Make a display of several insects that vector animal or plant diseases. Communicate the significance of those diseases, and how they may be controlled.
2. Study and observe the effects of pollution on insects by examining the differences of aquatic insects above and below a pollution or waste runoff site. Give a presentation about the effects of pollution on insects and what the consequences might be if these insects became extinct.
3. Design and grow a butterfly garden. Keep a written and photographic journal of dates, times, numbers, and types of butterflies that frequent the garden.
4. Visit a local agricultural supply store and make an inventory of the different insecticides they offer. Describe their uses and display how to use and dispose of these products safely. You might instead tour a local greenhouse to find out their insect issues and provide a summary of their management program.
5. Study various career opportunities available in entomology and interview an expert about career preparation and his/her likes and dislikes about the job. Write a children's story telling the pros and cons of working with insects.

Insect Pinning

Pinning: Pinning your insects will be the most difficult and frustrating part of your project. Making a complete and neat collection takes time and a lot of patience! Always collect more specimens than you think you need so that you can practice your technique. Use entomology pins for your collection – sewing pins are not recommended because they rust and can destroy your specimens.

Pins can be purchased at the Iowa State University Book Store in Ames, www.ubs.iastate.edu. You can also order pins and other entomology supplies online at www.bioquip.com. There are several sizes available, but #2 is the most common pin size.

Where to put the pin



Hymenoptera

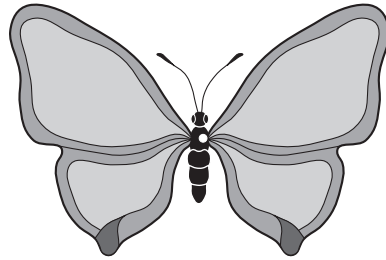

Lepidoptera



Orthoptera



Hemiptera

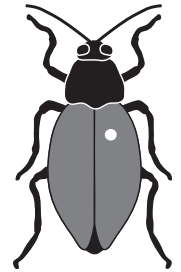

Coleoptera

- All pins should be placed in the thorax, slightly off to the right of the midline. Pins should be vertical to the insect. About $\frac{1}{3}$ to $\frac{1}{4}$ of the pin should remain above the insect, so you can handle it properly. To ensure neatness and uniformity in your collection, use the top step of a pinning block (Figure A).

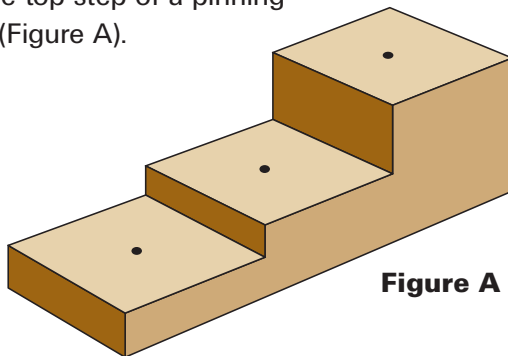

Figure A

- Pins should go directly into the thorax of most insects, including Diptera, Hymenoptera, and Lepidoptera. Pins should go through the pronotum of Orthoptera and true bugs within Hemiptera. Place the pin through the forewing of Coleoptera and Dermaptera.

- Carefully press the pinned insect into a foam insulation sheet until the body touches. Carefully maneuver the legs and antennae away from the body with an extra pin, so that they dry in a relatively "normal" position. Use additional pins to hold the body parts until they fully dry, about one week.

Special pinning: In some cases, you may wish to spread the wings of particularly beautiful insects for display. The most common examples are butterflies, moths, and dragonflies. Spreading insect wings takes special care because they are very delicate. The wings should be open and flat so that you can see the wing patterns. A foam insulation board can be used to make a platform for spreading and drying wings.

Cut a groove down the middle of the board about $\frac{1}{2}$ " wide and $\frac{1}{2}$ " deep (Figure B).

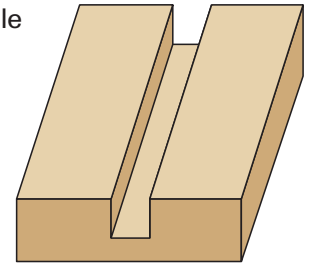
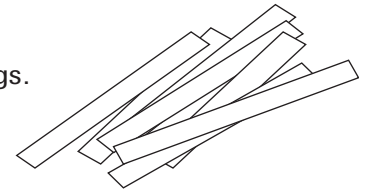

Figure B

Set the pinned insect inside the groove so the wings can lie flat on the board to dry. Use additional pins to secure the body from twisting while spreading the wings. Cut several small strips of paper to hold the wings flat while drying.



Place a strip over the forewing and gently push down until it is flat against the board (Figure C). Pin the slip of paper onto the board, but do not put a pin through the wing (Figure D).

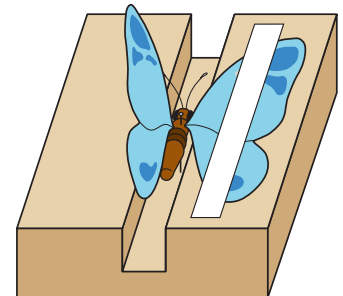

Figure C

Drag the wing up or down as necessary for display. Typically the bottom of the forewing should be at a 90-degree angle to the body. Repeat with the hindwing, using multiple pieces of paper and pins if needed. The hindwing usually is displayed with the top part just under the forewing. Repeat with the other side. Let them dry for at least a week and then (carefully!) transfer them to permanent storage.

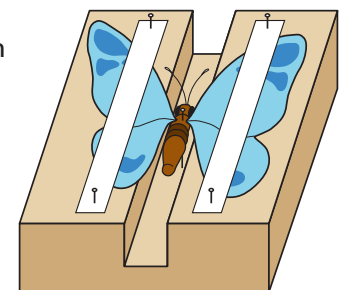

Figure D

Putting it all together.

Is your exhibit a proper insect collection? Here are some things you need to prepare a successful exhibit.

References: Find books at the library or bookstore that include common insects.

A Golden Guide of Insects, ISBN 9781582381299 (\$7)

National Audubon Society Insect Field Guides, ISBN 9780394507637 (\$13)

Also, use the Internet to help identify your specimens.

<http://bugguide.net>

<http://www.insects.org/entophiles>

How many do you need?

A beginner collection should display at least 5 orders and 25 species. An advanced general collection should have at least 15 orders and 110 species. When displaying insect life cycles, include 5 different insect species in at least 2 orders. For insects that undergo complete metamorphosis, all stages except the egg should be displayed. For insects that undergo simple metamorphosis, display at least three stages of development.

Storage and display

To store and display your project for a short time, use a cigar box or shoe box. Be sure to place a piece of cork in the bottom to secure the pinned specimens. For long-term storage, use a tight-fitting box to avoid having other insects destroy your collection.

Make your own display box

A standard entomology display box is 24" x 18" x 3 1/2" deep, and has a glass lid. Include a bottom liner of soft cork or balsa wood. Mothballs or crystals can be put in the corner to stop other insects from destroying your collection.

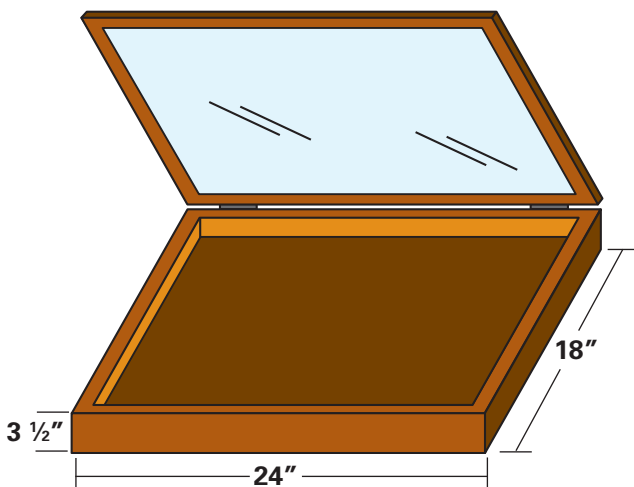

Labeling

Two labels are needed for each specimen after they have dried completely. Use stiff paper (e.g., index cards or cardstock) so they don't bend or droop. Write in ink or use a computer printer (4-point font). Labels should be placed below the pinned insect. The top label should contain 1) collection location, 2) date collected, and 3) collector's name. The bottom label could contain 1) identification (Order: Family), including common name; 2) collection habitat, and 3) collection method. Use a pinning block to make sure all the labels are at the same height; this will improve the appearance of a collection.

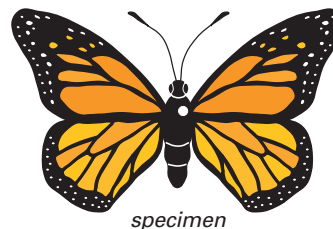

Story County, Iowa USA
McFarland Park, Ames
42°05'N 93°34'W
8 Sept 2010
E. W. Hodgson

top label

Monarch butterfly
Coleoptera: Coccinellidae
Plant: flower bed
Coll: sweep net

bottom label

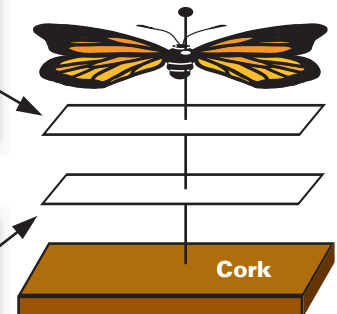

Revised by Erin Hodgson, ISU extension entomologist. Originally prepared by Marsha Morgan, 4-H youth specialist; Judy Levings, 4-H youth development specialist; and Ken Holscher, associate professor of entomology.

The U.S. Department of Agriculture (USDA) prohibits discrimination in all its programs and activities on the basis of race, color, national origin, age, disability, and where applicable, sex, marital status, familial status, parental status, religion, sexual orientation, genetic information, political beliefs, reprisal, or because all or part of an individual's income is derived from any public assistance program. (Not all prohibited bases apply to all programs.) Persons with disabilities who require alternative means for communication of program information (Braille, large print, audiotape, etc.) should contact USDA's TARGET Center at 202-720-2600 (voice and TDD). To file a complaint of discrimination, write to USDA, Director, Office of Civil Rights, 1400 Independence Avenue SW, Washington, DC 20250-9410, or call 800-795-3272 (voice) or 202-720-6382 (TDD). USDA is an equal opportunity provider and employer.

Issued in furtherance of Cooperative Extension work, Acts of May 8 and June 30, 1914, in cooperation with the U.S. Department of Agriculture. Gerald A. Miller, interim director, Cooperative Extension Service, Iowa State University of Science and Technology, Ames, Iowa.